



© Maschinenfabrik ALPINE Kessler GmbH

**Contact your local dealer:**

[https://www.cat.com/en\\_US/by-industry/marine/mak-dealer-locator.html](https://www.cat.com/en_US/by-industry/marine/mak-dealer-locator.html)

**Visit us on Shipped at:**

<http://www.shipserv.com/search/results/index/zone/mak>

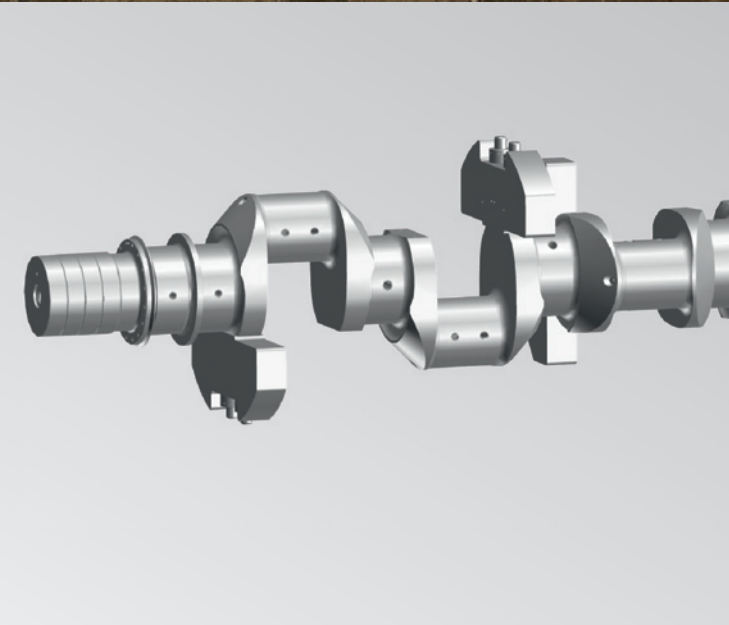

**Caterpillar Motoren GmbH & Co.KG**

Falckensteiner Str. 2  
24159 Kiel/Germany

Phone: +49 431 3995 01  
Telefax: +49 431 3995 2193

**For more information please visit our website:**  
[cat.com/marine](http://cat.com/marine)

Subject to change without notice.  
Leaflet No. 439 · 07.18 · e · L+S · VM3  
LEB00006-00

© 2018 Caterpillar. All rights reserved. Printed in Germany. CAT, CATERPILLAR, their respective logos, MaK, ACERT, ADEM, "Caterpillar Yellow" and the POWER EDGE trade dress, as well as corporate identity used herein, are trademarks of Caterpillar and may not be used without permission.

 Caterpillar Motoren is committed to sustainability.  
PEFC This document is printed on PEFC certificated paper.

# Crankshaft Heat Treatment

## MaK Repair Intelligence



MaK Repair Intelligence



## Introduction

The method used to manipulate the hardness or strength of a steel component is usually referred to as hardening, tempering or heat treatment. During such a process, the microstructure of the material is usually changed from martensitic to ferritic/perlitic. This process exposes the steel to very high temperatures and comprises a number of risks if done incorrectly.

From an engineering standpoint, heat treatment, in particular if applied to an individual section of a crankshaft, is critical. The characteristics of the surface of the treated journal can be verified and might achieve the desired condition, but the effect to areas inside the crankshaft is uncertain and cannot be measured. Due to the local exposure of the heat treatment, it is inevitable that there will be parts of the crankshaft that by heat transfer through the material will be subject to undefined heat treatment with unknown effects. As a result, these unknown effects are likely to have a negative influence on the fatigue strength and therefore the durability of the crankshaft.

In particular the presence of hard spots in a crankshaft is very undesirable. Over time these may lead to uneven wear and a significantly increased risk of cracks which may ultimately result in a broken crankshaft.

## What is the risk behind this procedure?

- The results are highly dependent on the type of material and tensile strength of the crankshaft as well as the process parameters being used.
- The knowledge of the exact material composition of the crankshaft is required in order to determine potential heat treatment parameters. The exact composition is usually not known by non-engine manufacturers who offer the crank.
- Metallurgical laboratory examination is needed to determine the achieved effects of the heat treatment.
- Crankshafts with surface cracks extending below the minimum rated diameter of the shaft cannot be salvaged by heat treatment.

- Overheating will result in undesired softening of the material and loss of tensile strength.
- Deformation of the crankshaft can occur during heat treatment. If the crankshaft cannot be kept within OEM tolerances there is a high probability that it could not be salvaged.
- Heat treatment often causes stress and strain related problems (cracks, deformation, distortion) during later operation. These may lead to consequences such as increased wear and tear resulting in secondary damage or catastrophic failure.

## Frequently Asked Questions

### What are most of the problems in heat treated parts attributed to?

Most issues in heat treated parts are attributed to faulty practices such as overheating, nonuniform heating, improper choice of parameters for the treated material and improper grinding and/or straightening techniques.

### Can heat treatment save all medium speed engine crankshafts with excessive hardness?

No, heat treatment cannot salvage crankshafts in cases where surface cracks extend below the minimum rated diameter of the shaft. Furthermore, excessive hardness induced from a bearing failure or as a result of inappropriate heat treatment often results in a deformation of the crankshaft. In cases when the crankshaft cannot be returned to the manufacturer's tolerances, with suitable methods, the shaft has to be condemned. Also, there are certain unique types of crankshafts, especially in newer engines, for which heat treatment is not an option.

### What are the benefits of crankshaft heat treatment to the owner?

The major benefits are usually a shorter repair time and lower costs compared to the exchange of a crankshaft. However, there is a high risk that at the end of the process the OEM tolerances are not achievable and/or laboratory examination shows that the material properties are out of specification.

### What is the difference between ferritic, austenitic and martensitic stainless steels?

By definition all steels including stainless steels are primarily made up of crystallized iron atoms with the addition of carbon. Ferrite, austenite and martensite are all examples of iron's crystal structures found within different types of steel and resulting in different characteristics. Furthermore, one of the defining difference between these crystal structures is the amount of carbon they can absorb; this has a major influence on the tensile strength and surface hardness.

### Does Caterpillar Motoren offer any warranty on heat treated crankshafts?

Due to the risks and complexities associated with such processes, Caterpillar Motoren does not recommend crankshaft heat treatment in general and therefore will not be responsible for any damage which arises as a result of the execution of this process.

**Progressive material tests are important components of our safety standards.**



Crankshaft Heat Treatment